

PENSKE
RACING SHOCKS®



PS-6020-RHS-X

Shaft Option, High-Speed Rebound

TECHNICAL MANUAL

Main Office

150 Franklin St. • P.O. Box 1056
Reading, PA 19603
(610) 375-6180 • (610) 375-6190 Fax

Table of Contents:

Introduction	p. 3
Terminology	p. 4
Build Procedure	p. 5
Adjustments	p. 7
Positive Stops	p. 8
Adjustment Mechanism	p. 9
Adjustment Range	p. 10
Dual-Bleed Check Poppets	p. 11
Warnings	p. 12
Troubleshooting	p. 13
Parts List	p. 14
Summary of Numbers	p. 15
Technical Support	p. 16



Introduction

Thank you for your purchase of your new Penske Racing Shocks PS-6020-RHS Shaft Option.

The PS-6020-RHS is the result of many years of successful competition in F1, Indy Car, and Sports Car. It provides a dramatically wider external adjustment range over a standard bleed bypass style shaft and is available for use in NASCAR (Sprint Cup, Nationwide, and Camping World Truck) and ARCA, among others.

Basic Features:

- *Preloaded shim cage locates on rebound base shim and applies compressive force*
- *Adjuster has 20 clicks of adjustment – each click = .002” of cage preload*
- *Positive detent for making adjustments even at stiff preload*
- *Can be used with any Penske 55mm piston including ELF, VB, and 2-Port*
- *Cage is secured with a top hat and lock nut for ease of setting preload and assembly*
- *Dual-bleed jets allow changing of bleed without disassembly of piston and shims to add bleed shims or drilling bleed holes.*
- *Dual-bleed jets allow independent, fixed bleed settings in bump and rebound*
- *Assembly includes EY-7321HS eyelet, NT-04Jjam nut, and COM-8T monoball*
- *Endurance tested for durability*
- *Track tested for performance*
- *Priced competitively to stay within budgets*
- *Ideal for impound races and changing track conditions where increased external adjustment is essential*
- *Allows one bump stop set-up to be used while sweeping force ranges without taking shock off the car*
- *Allows use of all standard Penske shims, shaft bearings, bodies, and tools*



Terminology:

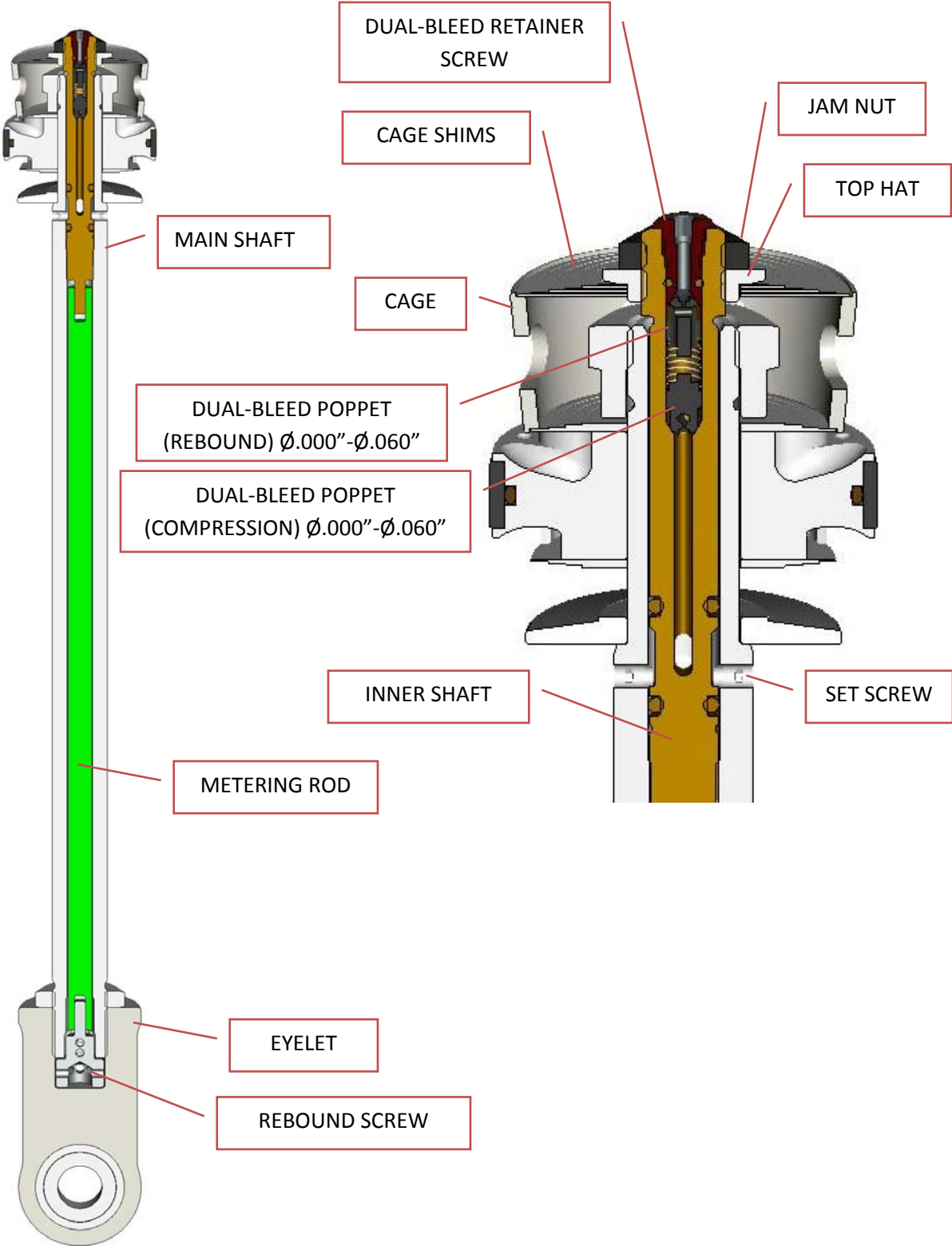

Build Procedure:

- 1.) Make sure the inner shaft is set so that a .040" gap exists between the end of the main shaft and the shoulder on the inner shaft. You may use shims to set this gap as it is difficult to accurately measure with calipers.

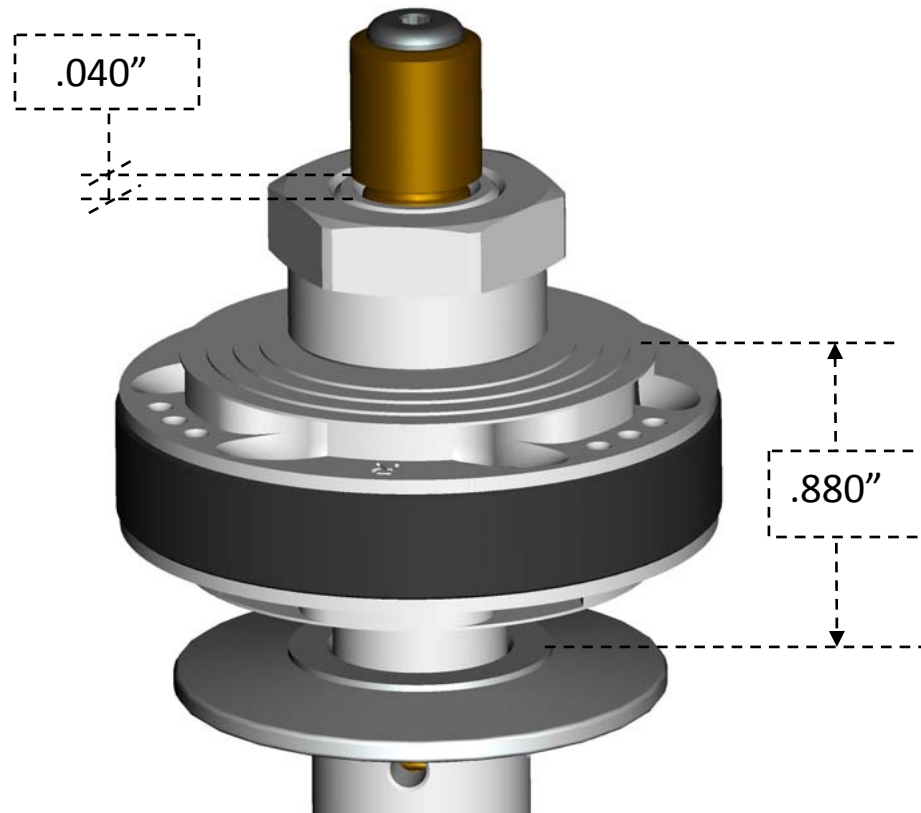

- 2.) Start with the particular piston type you plan to use and install a shim stack to corresponds to your SOFT setting or build for your rebound curve. The RHS shaft can only increase force, not make it softer for a given rebound shim stack.
- 3.) Although the exact stack up of the main piston and shims is not an absolute number due to the adjustable jam nut and top hat, we recommend a total height of .880", made up as follows:
PISTON THICKNESS (.600" for most Penske linear pistons) +
COMPRESSION STACK HEIGHT INCLUDING CONSTANTS +
the REBOUND BASE SHIM (1.350 in most cases or 1.475 for VB, etc.) =
.880"
- 4.) For thinner pistons, this results in more constants being used to reach the .880". For thicker pistons like the ELF or VB, the number of constants will be reduced.

5.) Install the Cage

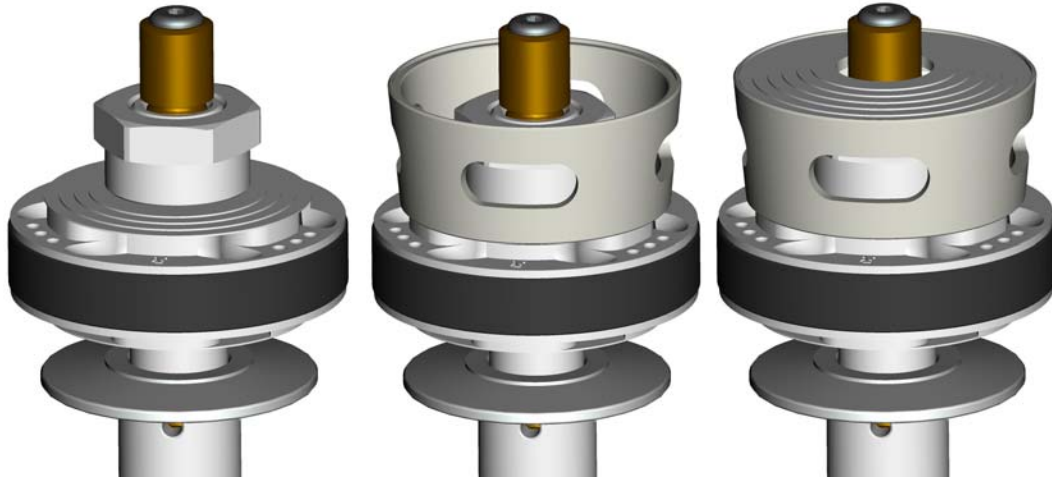

6.) Install the Cage Stack. Generally, this will be a full pyramid stack of .008" or .010" thick shims.

7.) Install the Top Hat. Please note: the threads of the nut and lock nut are LEFT HAND.

8.) Run the Top Hat onto the cage until desired resistance is achieved. A rule of thumb is that you do not want to allow the cage to "spin" freely but with moderate resistance.

9.) Run the Jam Nut onto the Top Hat with the flat side towards the top hat (i.e. no chamfer on surface).

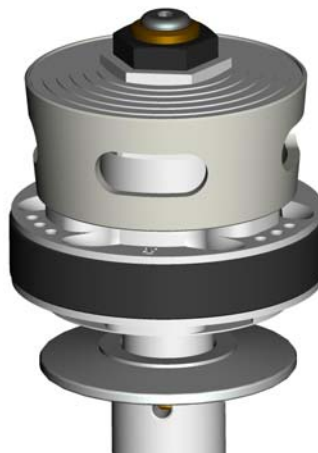

10.) Apply Loctite Primer 7649 and Loctite 243 (Blue) to Jam Nut.

11.) Holding the Top Hat in place with a thin wrench, use a socket with a turned down OD (to clear the wrench ID) and torque to **130 in lbs.**

Adjustments:

Use a .093" pin tool to sweep the adjuster window as with any Penske shaft. Clockwise is stiffer as the mechanism has a left hand thread. As the adjuster turns, the Inner Shaft is drawn into the shaft thus adding preload to the Cage Shims.

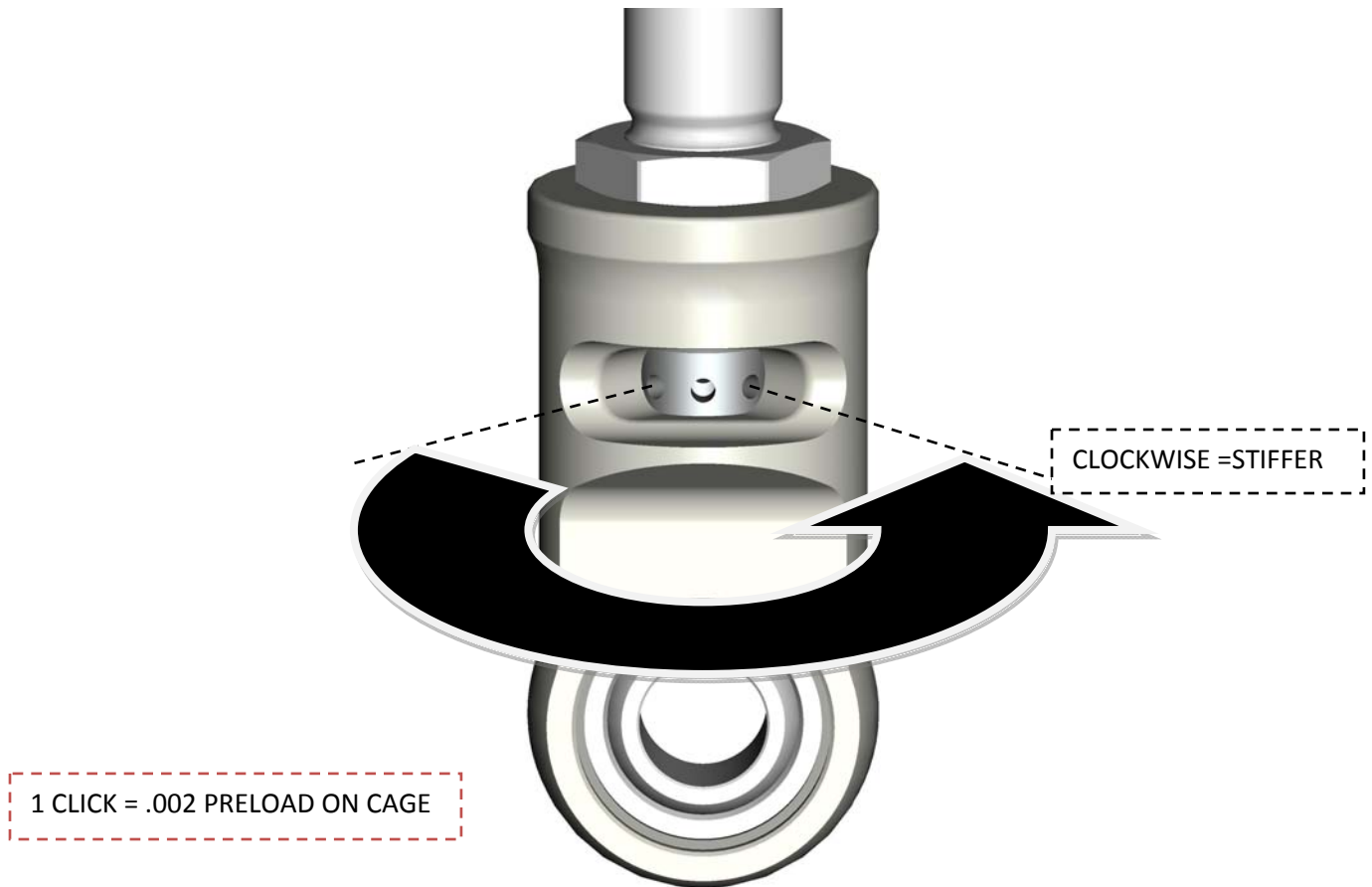

Positive Stops:

The shaft assembly has both positive stops in soft and stiff positions of the adjustment range. The full stiff positive stop is defined by the .040" gap between the Inner Shaft and the Main Shaft. The adjuster cannot add more preload than this gap.

The full soft position positive stop is defined by the set-screws in the shaft that locate on the Inner Shaft at its full soft travel position.

It is recommended to set the adjuster from the FULL SOFT position and add preload with the desired number of clicks. You may need to adjust the position of the Set Screws so that the full soft position is the same on all shafts. **Install the Set Screws with Loctite Primer 7649 and Loctite 242 (Red).** Run the screws in until they contact the Inner Shaft and back off 1/2 turn.

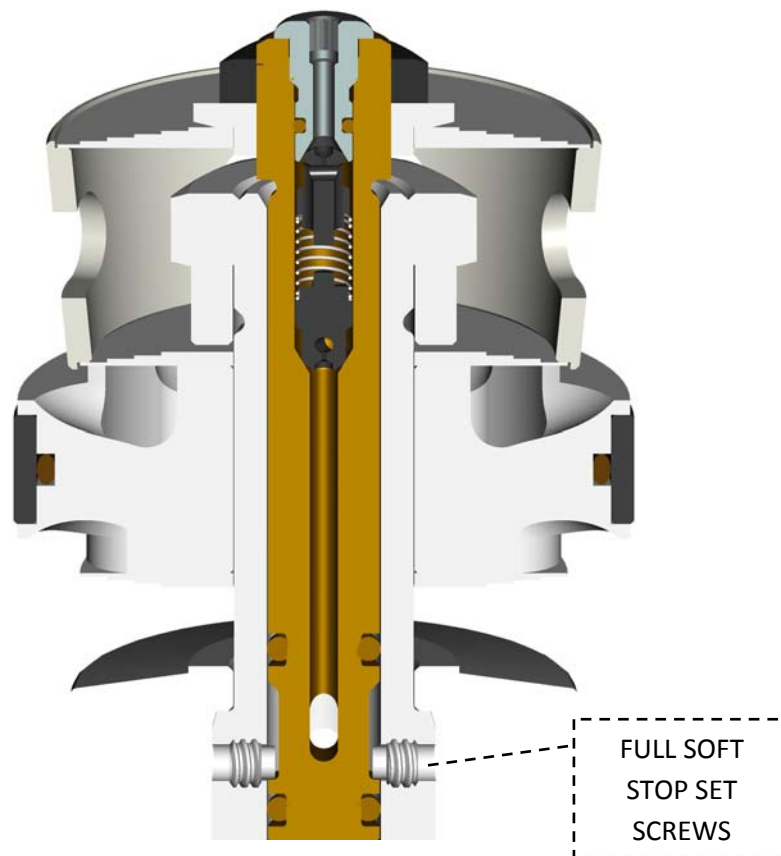

Adjustment Mechanism:

The adjustment mechanism of the PS-6020-RHS is different from other high-speed shafts in that the Inner Shaft is fixed to threads in the main shaft near the Main Shaft cross holes instead of at the end of the shaft. What this does is reduces the unconstrained length of the Inner Shaft to a much smaller value. As heat can be an issue in some shock applications, this type of arrangement has been found to be more stable with temperature. Additionally, the PS-6020-RHS uses the same material for the Inner and Main shaft to again keep the expansion of these components the same.

To accomplish this, the Metering Rod could not be attached directly to the Inner Shaft. Therefore, a tongue and groove arrangement was devised to connect the Metering Rod to the Inner Shaft. For additional manufacturing improvements, this same fixing arrangement was applied to the Rebound Screw/Metering Rod connection. The Rebound Screw simply rotates in position (does not go in and out) which rotates the Metering Rod which drives the Inner Shaft up and down in the Main Shaft threads.

Therefore, when completely disassembling the PS-6020-RHS shaft, keep in mind that if the eyelet is removed, the Rebound Screw and Metering Rod will both slide out of the end of the shaft easily. When re-assembling, keep in mind that the Metering Rod must be relocated in both the Inner Shaft tongue and the Rebound Screw tongue. If it is assembled properly, the Rebound Screw will be flush against the end of the shaft.

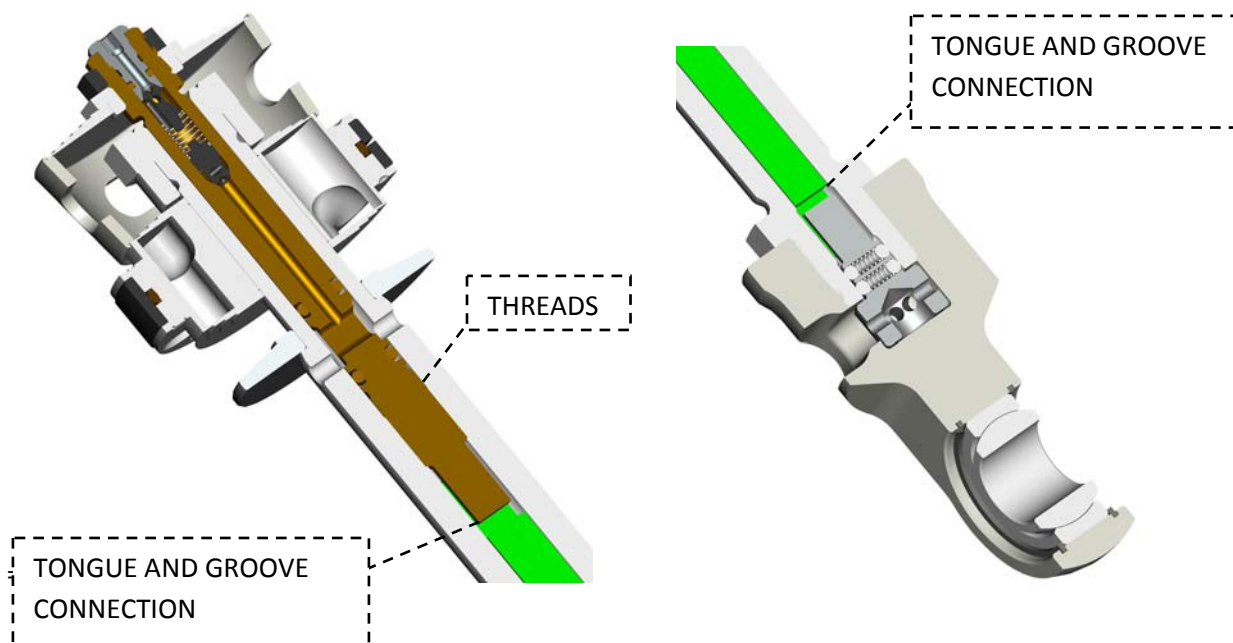

Adjustment Range:

The adjustment range will depend on the piston and cage. We have provided a basic example below of a standard adjustment spectrum.

Build Example:

- Piston: 1-4 High-Flow (PI-HF14005) / .000 Bleed
- Valving: A/3 X 1.35010, use .226" of .750s on compression side
- Cage Stack: 1.475 X .008, 1.350 x .008, 1.200 X .008, 1.050 X .008, .900 X .008 ("B")
- Dual-Bleed Poppet Bleed: CD (∅.010), RD (∅.010)
- Pressure: 100 psi
- Fluid: 2.5 wt

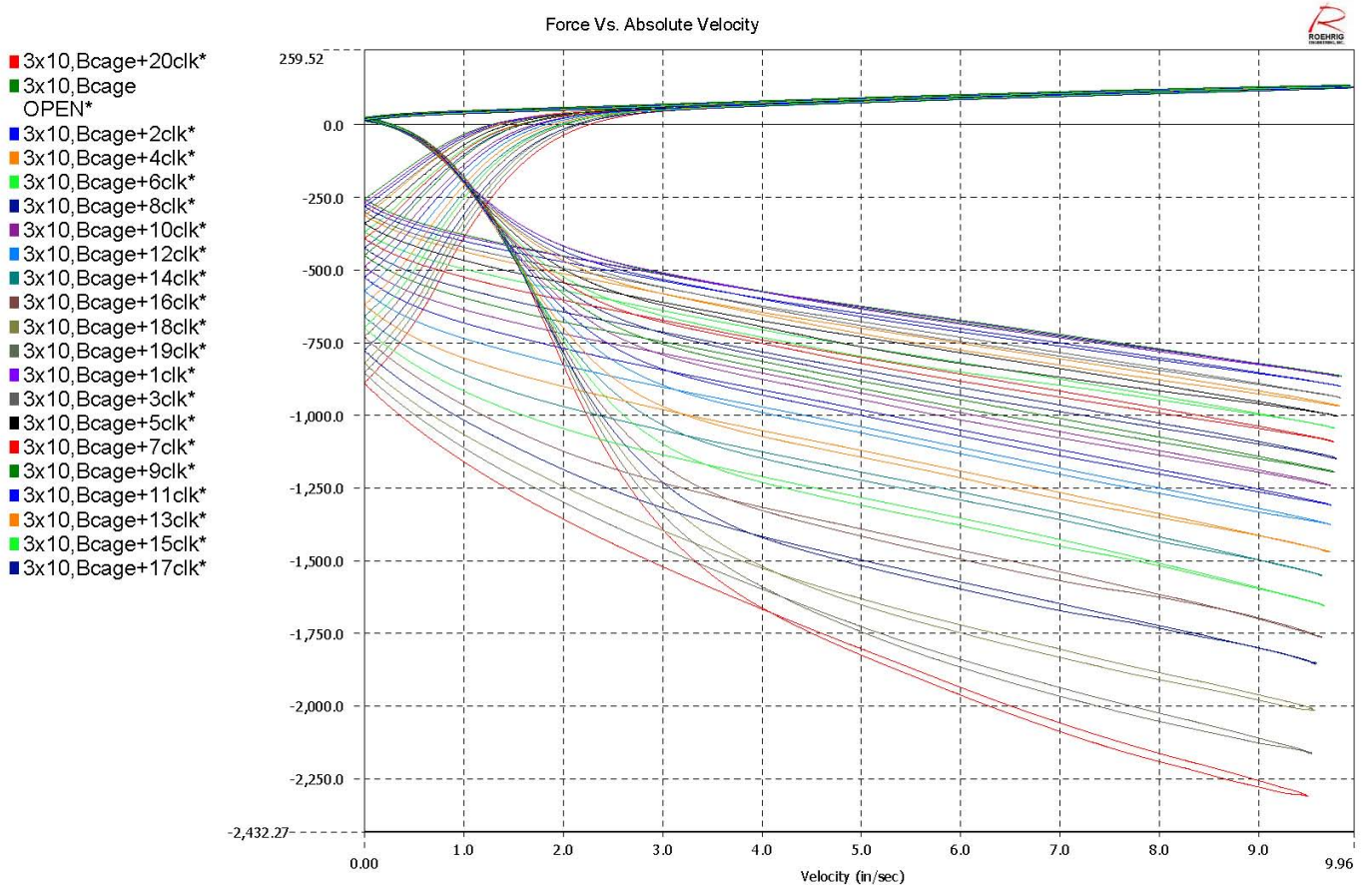

PS-6020-RHS
HIGH-FLOW BUILD EXAMPLE

Dual-Bleed Check Valve Poppets:

The dual-bleed check valve poppets allow the user to change the bleed across the piston without taking apart the cage and piston assembly and drilling bleed holes or installing a bleed shim. The effect of the dual-bleed poppet valves is the same as our standard VB piston in which one can run a symmetric amount of bleed in compression and rebound or staggered. The standard shaft will come with compression and rebound bleeds as specified by the customer. These can be drilled out with a standard mini drill press to change the bleed as needed or to experiment. The maximum hole size recommended is $\varnothing.060$. The minimum is $\varnothing.000$. The bleed relationship is essentially the same as a bleed shim although the poppets are slightly stiffer. Always check your shocks on the approved gauges before use in competition.

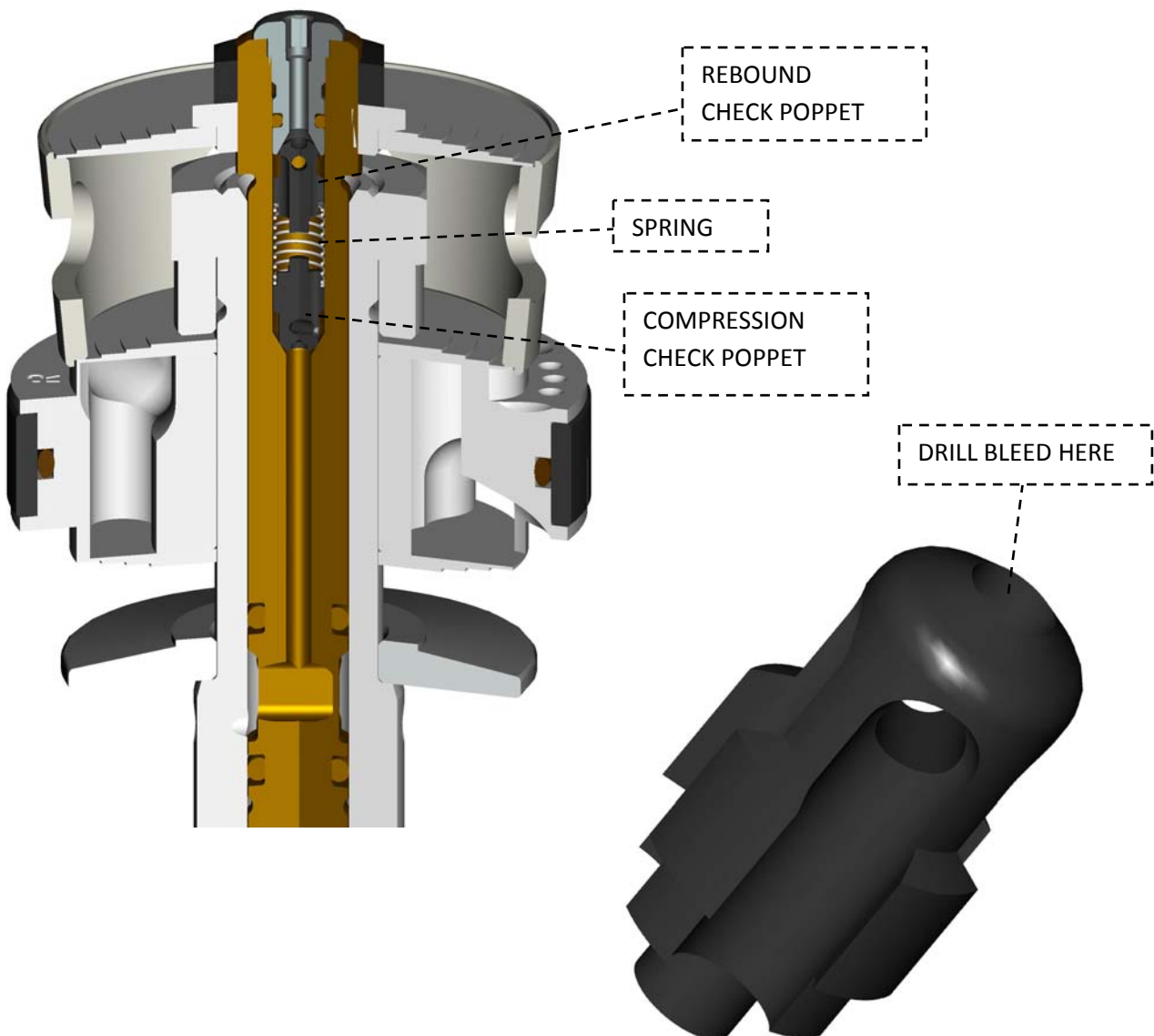

Warnings:

Penske Racing Shocks does not recommend excessive preload on cage shims. The maximum adjustment range is approximately 20 clicks or .040". Although you may build the cage assembly and set the inner shaft in a way to get more movement, we do not recommend it.

As the PS-6020-RHS is taller than a standard shaft assembly, ALWAYS check your stroke to make sure there are no internal clearance issues, especially if running a base valve. The PS-6020-RHS is .500" taller than a standard shaft, if measuring from the end of the shaft.

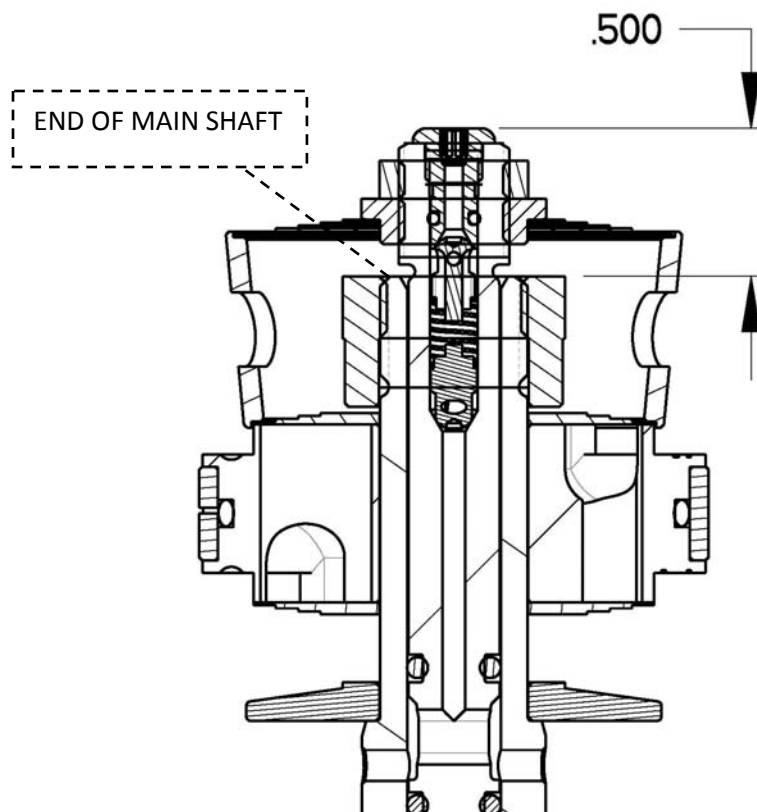

Troubleshooting:

Signs of Fluid:

If you see fluid coming from the eyelet, chances are you have cut an o-ring on the Inner Shaft. Replace the o-ring with an OR-2008-V.

Dislodgement Noise:

If the user fails to install the Full Soft Stop Set Screws, the Inner Shaft will be permitted to continue to extend from the end of the shaft, thus allowing the Cage and Cage Shims to become dislodged from the Top Hat. If this happens, the shock will be soft on the dyno and you will hear components moving around in the oil. The shaft will need to be completely disassembled and rebuilt.

Steps Between Clicks (in Force) Are Too Large:

Try softening the Cage Shims to get more compliance. This will reduce your range, but will make the steps between clicks smaller.

Bleed Does Not Match Your Expected Value:

If your low speed bleed curve is not correct, you may have debris in the Poppets. Remove the Dual-Bleed Retainer Screw and clean and replace Poppets. Please note - the Poppet bleed is very similar to piston bleed or bleed shims but may not be exactly the same slope due to different flow geometry.

Parts List:

PRIMER 7649 + BLUE LOCTITE (243)
130 in lbs

PRIMER 7649 + BLUE LOCTITE (243)
<10 in lbs (snug)

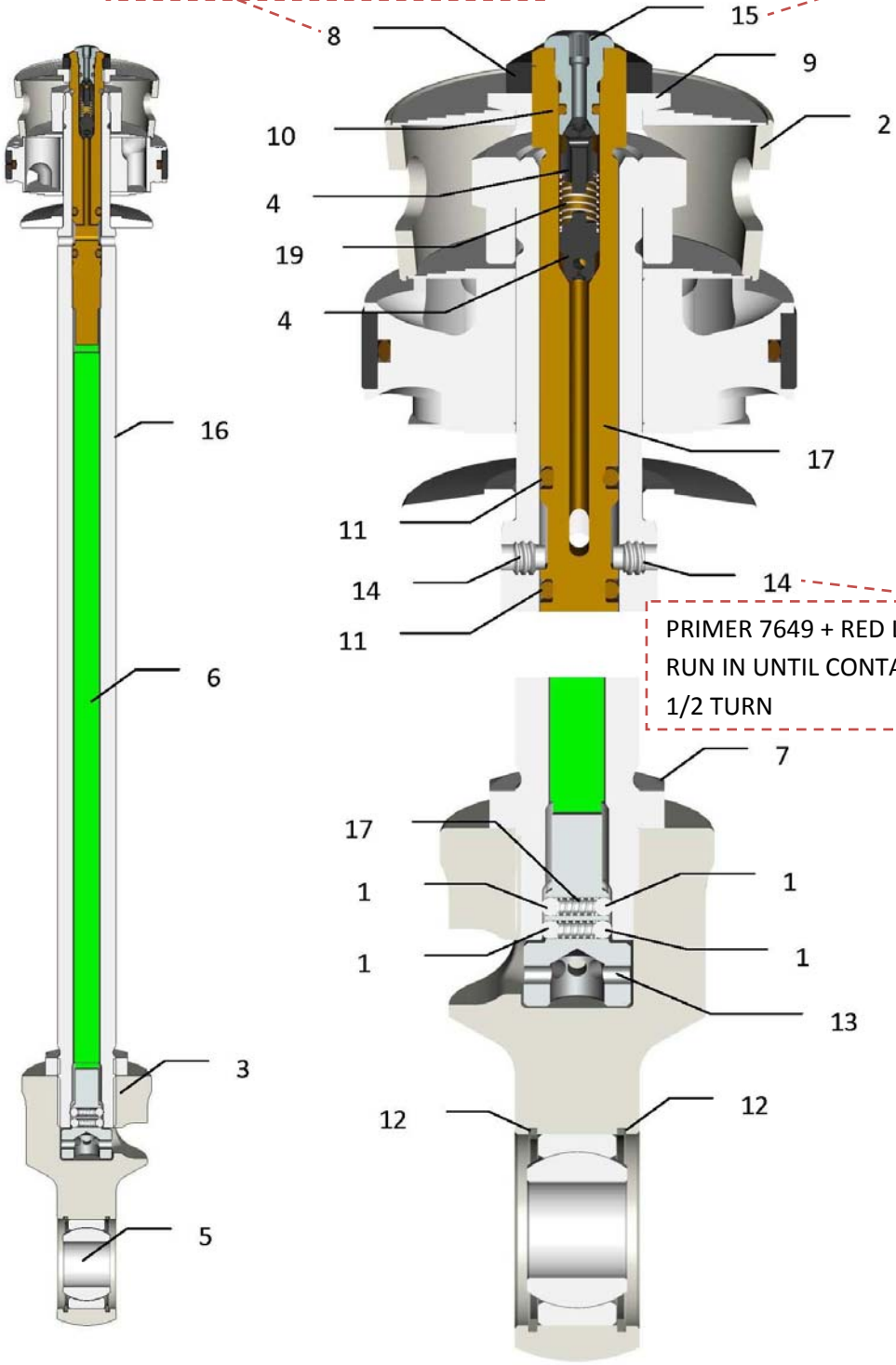

PRIMER 7649 + RED LOCTITE (242)
RUN IN UNTIL CONTACT, BACK OFF
1/2 TURN

Parts List:

Key	Part No.	Description	Quantity Per Unit
1	BA-093-ST	Ball, 3/32 Steel	4
2	CA-73HSR-1475	Cage, 7300 High Speed Rebound, 1.475"	1
3	EY-7321HS	Eyelet, 2.1" High Speed Blowoff	1
4	JT-DBCHK-084A	Dual Bleed Check Valve Poppet	2
5	MO-8T	Monoball, .500" ID X 1.00" OD	1
6	MR-RHS___	Metering Rod, RHS Shaft (160, 180, 200, 220, 240)	1
7	NT-04J	Jam Nut, .625 X 18	1
8	NT-76CDJ	Jam Nut, 8760 H/S CD Shaft Top Hat	1
9	NT-76CDT	Nut, 8760 H/S CD Shaft Top Hat	1
10	OR-2.5X1.0-V	O-ring, 2.5mm X 1.0mm Viton, Brown	1
11	OR-2008-B	O-ring, 2-008 Buna 70 Duro	2
12	RR-16	Retaining Ring, 1.025 Spiroloc Stainless	2
13	RS-73HSR	Screw, High Speed Rebound Blow-off	1
14	SC-125	Screw, Socket Set 6/32 X 125	2
15	SC-F1-DBCHK-RET	Screw, F1 Dual Bleed Check Retaining Ring	1
16	SH-___A-RHS	Shaft, Adjustable (8.625", 9.625", 10.500", 11.500", 12.500")	1
17	SH-RHS-INNER	Shaft, RHS Inner Locknut	1
18	SP-13	Spring, (M-6)	2
19	SP-17	Spring, (N-5)	1

Summary of Numbers:

1 Click = .002" Cage Preload

Poppet Bleed Available Range: Ø.000 to Ø.060

Number of Clicks per Turn: 12

Heat Capacity: 200°F+

Thread Pitch: 40 (LEFT HAND)

Compression Stack + Piston Thickness +
Rebound Base Shim Thickness = .880"

Total Clicks = 20-22

Recommended Torque/Loctite Specs:

Jam Nut (NT-76CDJ) 130 in lbs + PRIMER 7649 + BLUE LOCTITE 243

Dual-Bleed Retainer Screw (SC-F1-DBCHK-RET) 10 in lbs + PRIMER 7649 + BLUE LOCTITE 243

Full Soft Set Screws (SC-125) PRIMER 7649 + RED LOCTITE 242

Technical Support:

8:30 AM – 5:00 PM (EST)

Penske Racing Shocks – Technical Center
150 Franklin Street
Reading, PA 19602
United States

610.375.6180

Penske Racing Shocks Midwest
12666 U.S. Route 12
Brooklyn, MI 49230
United States

517.592.6681

www.penskeshocks.com



Rev. 01-2010